

BASE FIXING HOLES POSITION  
BOTTOM VIEW

2473

$\phi 12 (4x)$

997

RIGHT VIEW

800

1200

FRONT VIEW

LOW PRESSURE SIDE REFRIGERANT GAUGE  
HIGH PRESSURE SIDE REFRIGERANT GAUGE

COMPRESSED AIR INLET

COMPRESSED AIR OUTLET

ELECTRICAL SUPPLY CABLE INLET

600

COND. WATER OUTLET

COND. WATER INLET

1"1/4 BSBT-F for PSE1500/1800 50/60Hz (CE) version  
1"1/4 NPT-F for 60Hz (UL508A) version with adapters

LEFT VIEW  
2529 MAX.

2500

1900

PRE-PUNCHED HOLES FOR WATER CONNECTION

480

1222

475

450

195

123

250

CONDENSATE DRAIN  
1/2" BSPP-F CONNECTION

BACK VIEW  
1517 MAX.

1260

170

ELECTRICAL SUPPLY CABLE INLET

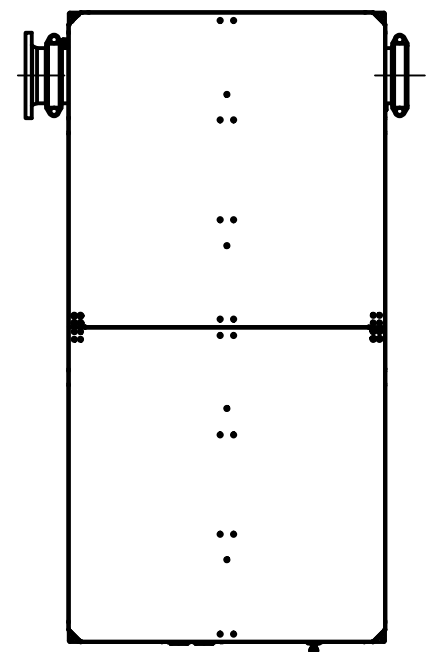
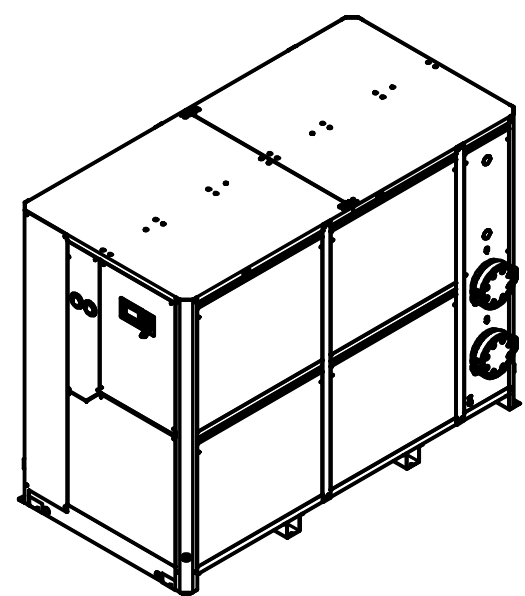
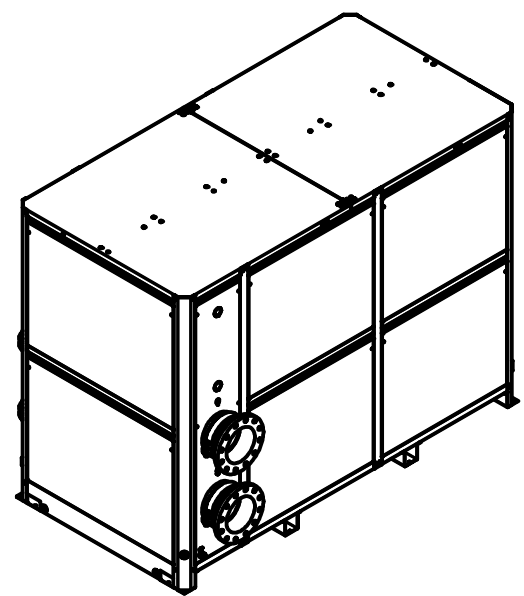

MODEL 50/60Hz (CE)	AIR CONNECTION 50/60Hz (CE) version	MODEL 60Hz (UL508A)	AIR CONNECT. 60Hz (UL508A) version
PSE 1500-1800	UNI-EN 1092-1 PN16-DN200	PSE 1500-5000 PSE 1800-6000	ANSI 8" - 150 LBS

**Parker Hannifin Manufacturing S.r.l.**  
Gas Separation and Filtration Division EMEA - Strada Zona Industriale, 4- 35020 - S. Angelo di Piove (PD) - ITALY

TOLERANCE UNI EN 22768 - mK UNI EN ISO 13920 - AE DIN 28005 ISO 1302	ECO <b>ECO-0290816</b> Checked/Approved by ENOVIA process		DESCRIPTION OVERALL DIM.PSE 1500-1800 SHELL & TUBES DIMENS.INGOMBRO PSE 1500-1800 FASCIO TUB.	
	AUTHOR MB238398	DATE 13/07/2021	DRAWING NO. <b>H39AB1800L003</b>	
ISO 128-30 Method 1	SCALE 1:30	MASS kg	REV. -	
UNITS MM	MATERIAL		JDE Cod. Art. (Optional)	FORMAT A3
			SHEET 1 / 1	

THIS DOCUMENT CONTAINS INFORMATION THAT IS CONFIDENTIAL AND PROPRIETARY TO PARKER HANNIFIN MANUFACTURING - GAS SEPARATION AND FILTRATION DIVISION EMEA. THIS DOCUMENT IS FURNISHED ON THE UNDERSTANDING THAT THE DOCUMENT AND THE INFORMATION IT CONTAINS WILL NOT BE COPIED OR DISCLOSED TO OTHERS OR USED FOR ANY PURPOSE OTHER THAN CONDUCTING BUSINESS WITH PARKER, AND WILL BE RETURNED AND ALL FURTHER USE DISCONTINUED UPON REQUEST BY PARKER. THE RECIPIENT OF THIS DOCUMENT THROUGH ITS OWN ANALYSIS AND TESTING IS SOLELY RESPONSIBLE FOR MAKING THE FINAL SELECTION OF THE APPLICABLE SYSTEM AND COMPONENTS AND ASSURING THAT ALL PERFORMANCE, ENDURANCE, MAINTENANCE, SAFETY AND WARNING REQUIREMENTS OF THE APPLICATION ARE MET. COPYRIGHT PARKER, YEAR OF COPYRIGHT IS FIRST YEAR INDICATED ON THIS DOCUMENT. ALL RIGHTS RESERVED. 2021 is a registered trademark owned by Parker Hannifin S.p.A.